

## C3052OD.109 Premium Series



### Premium Series 30" x 52" Walk-in Bath

The American Standard 30" x 52" Gelcoat walk-in bath provides a similar bathing experience to larger models but fits in smaller spaces and uses less water. The included tub extender allows this tub to retrofit in the same space as a standard bathtub. The full sized, outward opening, contoured door with a low door threshold allows ease of entry and exit.

Fully equipped, the 109 Premium Series offers all the latest in safety and comfort features with the most advanced therapeutic options and backed by a lifetime warranty on the door seal, a 10 year warranty on the tub shell and a 5 year warranty on all other components.

#### Whirlpool Massage



A soothing and invigorating water jet massage system, the Whirlpool massage features an in-line heater, an automatic tub cleaning system and Legs-Only massage. Customize back and leg muscle therapies with 12 different water jets. The Whirlpool Spa is combined with all of the features of the Soaker Tub providing an enhanced therapeutic bathing experience.

#### Combination System



Combines all of the features of the Soaker Tub, the Whirlpool Massage, and the Air Spa Systems, plus a multi-colored Chromatherapy light system for the ultimate therapeutic bathing experience. The Air Spa Systems provides a soft and caressing all-over body massage powered by a variable speed heated blower that releases thousands of air bubbles rising throughout the water from 26 different air jets. The automatic purge cycle helps keep the system running efficient and clean. The Air Spa is combined with all of the features of the Soaker Tub providing an enhanced therapeutic bathing experience.

#### Quick Drain® System



Spend less time waiting with this patented innovation, that requires no additional plumbing, once activated it rapidly pumps the water out from within the tub-making it safe to open the door and exit the tub. Included in all systems.

*American Standard*

LIFE.LOVE.HOME

# C3052OD.109-PC Premium Series 30" x 52" Walk-in Bath

## C3052OD.109.SXX-PC Soaking Tub

- Tub Extender Kit to fill 60" space
- Available in White with Left Hand or Right Hand Door/Drain Configuration
- Outward opening door with watertight door system with a lifetime warranty on the door seal
- Built-in chair height seat
- Polished chrome trim and cable driven waste and overflow
- Built-in safety bar and textured tub floor
- Cushioned neck rest
- Patented Quick Drain® fast water removal system
- Premium fast-fill tub faucet and handheld showering wand
- Partial seat transfer

## C3052OD.109.WXX-PC Whirlpool Massage System

Combines all of the features of the Soaking Tub, plus:

- Whirlpool in-line heater
- 12 massage jets with variable flow
- Legs-only massage
- Self-cleaning sanitation system

## C3052OD.109.CXX-PC Combination System

Combines all of the features of the Soaker Tub and the Air Spa Systems for the ultimate therapeutic bathing experience, plus:

- Multi-colored Chromatherapy light system positioned at the bottom of the bath that creates a peaceful bathing experience
- Variable speed heated blower
- 26 seat and floor air injectors
- Automatic purge cycle

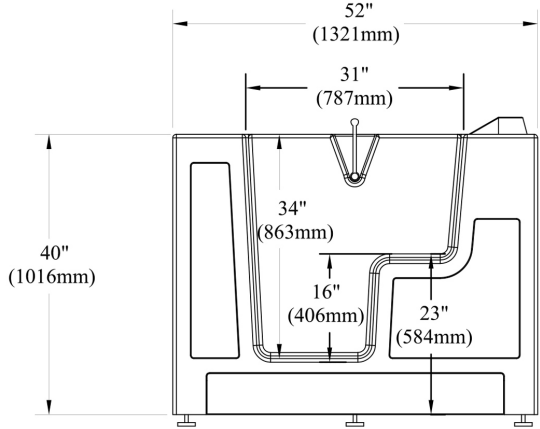
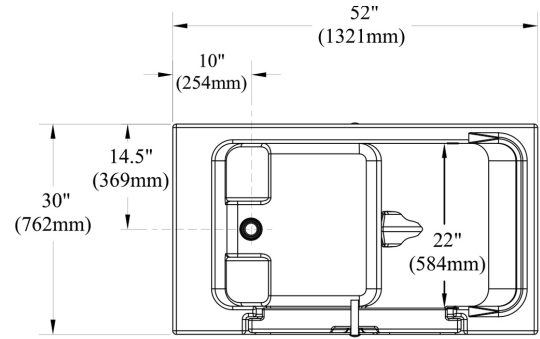

### GENERAL SPECIFICATIONS FOR C3052OD.109.XXX-PC WALK-IN BATHTUB

INSTALLED SIZE	_____ 52 x 30 x 40 In. (1320 x 762 x 1016mm)
WEIGHT	_____ 155 Lbs. (70 Kg.)
WEIGHT w/WATER	_____ 781 Lbs. (354 Kg.)
OPERATING GALLON	_____ 75 Gal. (284 L.)
FLOOR LOADING	_____ 73 Lbs./Sq. Ft. (356 Kgs/Sq. m.)
(PROJECTED AREA)	
CUBE (FT <sup>3</sup> )	_____ 36.1

### To Be Specified - Required:

- Drain Configuration: Left (L) or Right (R)

### Options:

- Handshower Glide Bar: 9HSB  
 24 inch Grab Bar: 9GB-24



Designed for pain relief & easy use

**Notes:** The whirlpool heater is designed to maintain water temperature during operation. It will not heat cold water to desired bathing temperature. Tub is supported by the frame and five integrated adjustable feet, no additional support required. Refer to installation instructions supplied with tub for additional information. Provide suitable reinforcement to sub floor for all supports.

**Our products are in compliance with the following codes:** Uniform Plumbing Code UPC®; National Plumbing Code of Canada; International Plumbing Code IPC®

**Our products conform to the following standards:** ASME A112.19.7, ASME A112.19.15; CSA B45, CSA B45.5; CSA C22.2 No. 218.2; UL-1795; ANSI Z124.1.2

**Our products are listed with:** c ETL us

**IMPORTANT:** Dimensions of fixtures are nominal, may vary and are subject to change or cancellation. No responsibility is assumed for use of superseded or voided leaflet.

*American Standard*