

C3051.119 Luxury Series



Luxury Series 30" x 51" Walk-in Bath

The American Standard 30" x 51" Acrylic walk-in bath provides a similar bathing experience to larger models but fits in smaller spaces and uses less water. The included tub extender allows this tub to retrofit in the same space as a standard bathtub. The full sized, contoured door with a low door threshold allows ease of entry and exit.

Fully equipped, the 119 Luxury Series offers all the latest in safety and comfort features with the most advanced therapeutic options and backed by a lifetime warranty on the door seal, a 15 year warranty on the tub shell and a 10 year warranty on all other components.

Whirlpool Massage



A soothing and invigorating water jet massage system, the Whirlpool massage features an in-line heater, an automatic tub cleaning system and Legs-Only massage. Customize back and leg muscle therapies with 13 different water jets. The Whirlpool Spa is combined with all of the features of the Soaker Tub providing an enhanced therapeutic bathing experience.

Air Spa Massage



Experience a soft and caressing all-over body massage powered by a variable speed heated blower that releases thousands of air bubbles rising throughout the water from 26 different air jets. The automatic purge cycle helps keep the system running efficient and clean. The Air Spa is combined with all of the features of the Soaker Tub providing an enhanced therapeutic bathing experience.

Combination System



Combines all of the features of the Soaker Tub, the Whirlpool Massage and the Air Spa Systems, plus a multi-colored Chromatherapy light system for the ultimate therapeutic bathing experience.

American Standard

LIFE.LOVE.HOME

C3051.119 Luxury Series 30" x 51" Walk-in Bath

C3051.119.SXX Soaking Tub

- Tub Extender Kit to fill 60" space
- Available in White with Left Hand or Right Hand Door/Drain Configuration
- Patented watertight door system with a lifetime warranty on the door seal
- Built-in chair height seat
- Color matched trim and cable driven waste and overflow
- Built-in safety bar and textured tub floor
- Cushioned neck rest
- Patented Quick Drain® fast water removal system
- Premium fast-fill tub faucet and handheld showering wand

C3051.119.WXX Whirlpool Massage System Combines all of the features of the Soaking Tub, plus:

- 13 massage jets with variable flow
- Legs-only massage
- Whirlpool in-line heater
- Self-cleaning sanitation system

C3051.119.CXX Combination System Combines all of the features of the Soaker Tub and the Whirlpool Massage System, plus the Air Spa System features and Chromatherapy for the ultimate therapeutic bathing experience:

- 26 seat and floor air injectors
- Variable speed heated blower
- Automatic purge cycle
- Multi-colored Chromatherapy light system positioned at the bottom of the bath that creates a peaceful bathing experience

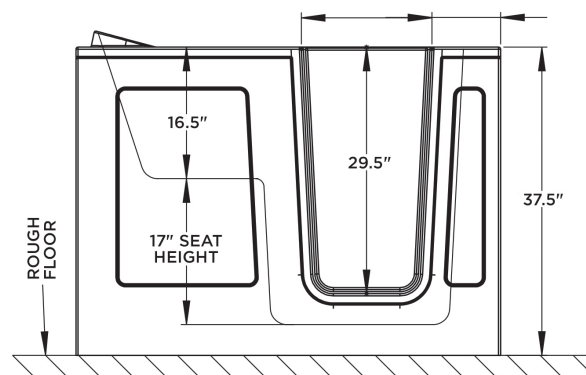
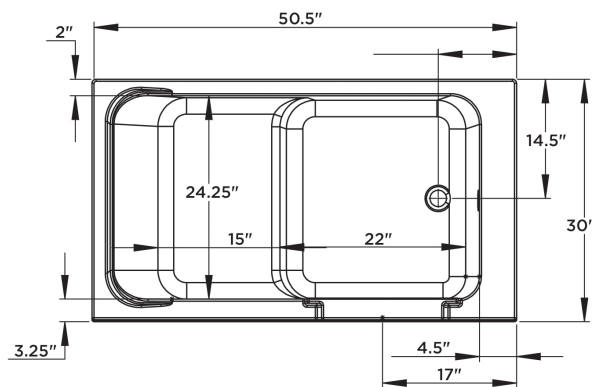

GENERAL SPECIFICATIONS FOR C3051.119.XXX WALK-IN BATHTUB

INSTALLED SIZE	51 x 30 x 37 In. (1295 x 762 x 940mm)
WEIGHT	150 Lbs. (68 Kg.)
WEIGHT w/WATER	525 Lbs. (238 Kg.)
OPERATING GALLON	55 Gal. (208 L.)
FLOOR LOADING (PROJECTED AREA)	49 Lbs./Sq. Ft. (240.25 Kgs./Sq. m.)
CUBE (FT ³)	32.8

To Be Specified - Required:

- Drain Configuration: Left (L) or Right (R)

Options:

- Handshower Glide Bar: 9HSB
- 24 inch Grab Bar: 9GB-24
- End Panel for Seat Side
- End Panel for Faucet Side
- End Panel for Backside



Designed for pain relief & easy use

Notes: The whirlpool heater is designed to maintain water temperature during operation. It will not heat cold water to desired bathing temperature. Tub is supported by the frame and five integrated adjustable feet, no additional support required. Refer to installation instructions supplied with tub for additional information. Provide suitable reinforcement to sub floor for all supports.

Our products are in compliance with the following codes: Uniform Plumbing Code UPC®; National Plumbing Code of Canada; International Plumbing Code IPC®

Our products conform to the following standards: ASME A112.19.7, ASME A112.19.15; CSA B45, CSA B45.5; CSA C22.2 No. 218.2; UL-1795; ANSI Z124.1.2

Our products are listed with: c ETL us

IMPORTANT: Dimensions of fixtures are nominal, may vary and are subject to change or cancellation. No responsibility is assumed for use of superseded or voided leaflet.

American Standard