

C3060.109 Premium Series



Premium Series 30" x 60" Walk-in Bath

The American Standard 30" x 60" Gelcoat walk-in bath provides the maximum in therapeutic soaking pleasure with the largest water capacity in our product line. The full sized, contoured door with a low door threshold allows ease of entry and exit.

Fully equipped, the 109 Premium Series offers all the latest in safety and comfort features with the most advanced therapeutic options and backed by a lifetime warranty on the door seal, a 10 year warranty on the tub shell and a 5 year warranty on all other components.

Air Spa Massage



Experience a soft and caressing all-over body massage powered by a variable speed heated blower that releases thousands of air bubbles rising throughout the water from 26 different air jets. The automatic purge cycle helps keep the system running efficient and clean.

The Air Spa is combined with all of the features of the Soaker Tub providing an enhanced therapeutic bathing experience

Combination System



Combines all of the features of the Soaker Tub, the Air Spa and the Whirlpool Massage Systems, plus a multi-colored Chromotherapy light system for the ultimate therapeutic bathing experience. A soothing and invigorating water jet massage system, the Whirlpool massage features an in-line heater, an automatic tub cleaning system and Legs-Only massage. Customize back and leg muscle therapies with 13 different water jets. The Whirlpool Spa is combined with all of the features of the Soaker Tub providing an enhanced therapeutic bathing experience.

Quick Drain® System



Spend less time waiting with this patented innovation, that requires no additional plumbing, once activated it rapidly pumps the water out from within the tub-making it safe to open the door and exit the tub. Included in all systems.

American Standard

LIFE.LOVE.HOME

C3060.109 Premium Series 30" x 60" Walk-in Bath

C3060.109.SXW Soaking Tub

- Available in White in Left Hand or Right Hand Door/Drain Configuration
- Watertight door system with a lifetime warranty on the door seal
- Built-in chair height seat
- Color matched trim and cable driven waste and overflow
- Built-in safety bar and textured tub floor
- Cushioned neck rest
- Patented Quick Drain® fast water removal system
- Premium fast-fill tub faucet and handheld showering wand

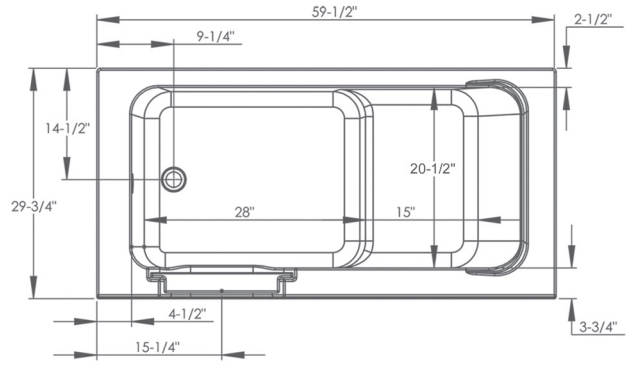

C3060.109.AXW Air Spa System

Combines all of the features of the Soaking Tub, plus:

- Variable speed heated blower
- 26 seat and floor air injectors
- Automatic purge cycle

C3060.109.CXW Combination System

Combines all of the features of the Soaker Tub, the Air Spa and Whirlpool Massage Systems for the ultimate therapeutic bathing experience, plus:

- Multi-colored Chromatherapy light system positioned at the bottom of the bath that creates a peaceful bathing experience
- Whirlpool in-line heater
- 12 massage jets with variable flow
- Legs-only massage
- Self-cleaning sanitation system

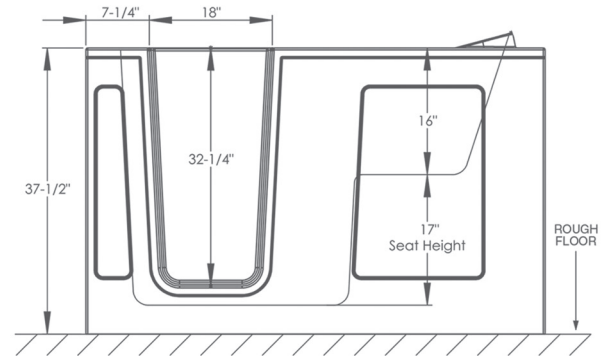

GENERAL SPECIFICATIONS FOR C3060.109.XXW WALK-IN BATHTUB

INSTALLED SIZE	60 x 30 x 37 In. (1524 x 762 x 940mm)
WEIGHT	150 Lbs. (68 Kg.)
WEIGHT w/WATER	900 Lbs. (408 Kg.)
OPERATING GALLON	75 Gal. (284 L.)
FLOOR LOADING	73 Lbs./Sq. Ft. (275 Kgs/Sq. m.)
(PROJECTED AREA)	
CUBE (FT ³)	38.5

To Be Specified - Required:

- Drain Configuration: Left (L) or Right (R)

Options:

- Handshower Glide Bar: 9HSB
- 24 inch Grab Bar: 9GB-24



Designed for pain relief & easy use

Notes: The whirlpool heater is designed to maintain water temperature during operation. It will not heat cold water to desired bathing temperature. Tub is supported by the frame and five integrated adjustable feet, no additional support required. Refer to installation instructions supplied with tub for additional information. Provide suitable reinforcement to sub floor for all supports.

Our products are in compliance with the following codes: Uniform Plumbing Code UPC®; National Plumbing Code of Canada; International Plumbing Code IPC®

Our products conform to the following standards: ASME A112.19.7, ASME A112.19.15; CSA B45, CSA B45.5; CSA C22.2 No. 218.2; UL-1795; ANSI Z124.1.2

Our products are listed with: c ETL us

IMPORTANT: Dimensions of fixtures are nominal, may vary and are subject to change or cancellation. No responsibility is assumed for use of superseded or voided leaflet.

American Standard