

## C3060.509 Value Series



### Value Series 30" x 60" Walk-in Bath

The American Standard 30" x 60" Gelcoat walk-in bath provides the maximum in therapeutic soaking pleasure with the largest water capacity in our product line. The full sized, contoured door with a low door threshold allows ease of entry and exit.

Fully equipped, the 509 Value Series offers all the latest in safety and comfort features bundled together at one low cost and backed by a lifetime warranty on the door seal, a 10 year warranty on the tub shell and a 5 year warranty on all other components.

#### Whirlpool Massage



A soothing and invigorating water jet massage system, the Whirlpool massage features an in-line heater and Legs-Only massage. Customize back and leg muscle therapies with 8 different water jets. The Whirlpool Spa is combined with all of the features of the Soaker Tub providing an enhanced therapeutic bathing experience.

#### Air Spa Massage



Experience a soft and caressing all-over body massage powered by a single speed heated blower that releases thousands of air bubbles rising throughout the water from 21 different air jets. The automatic purge cycle helps keep the system running efficient and clean. The Air Spa is combined with all of the features of the Soaker Tub providing an enhanced therapeutic bathing experience.

#### Combination System



Combines all of the features of the Soaker Tub, the Air Spa and the Whirlpool Massage Systems for the ultimate therapeutic bathing experience.

*American Standard*

LIFE.LOVE.HOME

# C3060.509 Value Series 30" x 60" Walk-in Bath

## C3060.509.SXW Soaking Tub

- Available in White with Left Hand or Right Hand Door/Drain Configuration
- Watertight door system with a lifetime warranty on the door seal
- Built-in chair height seat
- Color matched trim and cable driven waste and overflow
- Built-in safety bar and textured tub floor
- Patented Quick Drain® fast water removal system
- Premium tub faucet and handheld showering wand

## C3060.509.WXW Whirlpool Massage System

Combines all of the features of the Soaking Tub, plus:

- 8 massage jets with variable flow
- Legs-only massage
- Whirlpool in-line heater

## C3060.509.CXW Combination System

Combines all of the features of the Soaker Tub and the Whirlpool Massage for the ultimate therapeutic bathing experience, plus the Air Spa System:

- 21 seat and floor air injectors
- Single speed heated blower
- Automatic purge cycle

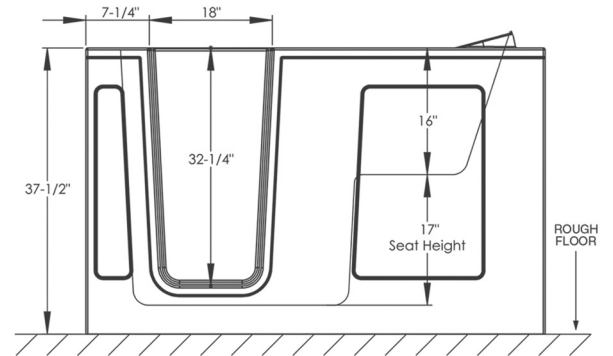
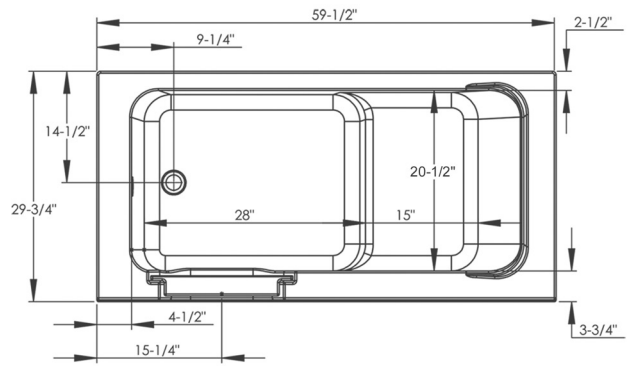

### GENERAL SPECIFICATIONS FOR C3060.509.XXW WALK-IN BATHTUB

INSTALLED SIZE	60 x 30 x 37 In. (1524 x 762 x 940mm)
WEIGHT	150 Lbs. (68 Kg.)
WEIGHT w/WATER	900 Lbs. (408 Kg.)
OPERATING GALLON	75 Gal. (284 L.)
FLOOR LOADING (PROJECTED AREA)	73 Lbs./Sq. Ft. (275 Kgs/Sq. m.)
CUBE (FT <sup>3</sup> )	38.5

### To Be Specified - Required:

- Drain Configuration: Left (L) or Right (R)

### Options:

- Handshower Glide Bar: 9HSB
- 24 inch Grab Bar: 9GB-24
- Neck Rest: 9NR



Designed for pain relief & easy use

**Notes:** The whirlpool heater is designed to maintain water temperature during operation. It will not heat cold water to desired bathing temperature. Tub is supported by the frame and five integrated adjustable feet, no additional support required. Refer to installation instructions supplied with tub for additional information. Provide suitable reinforcement to sub floor for all supports.

**Our products are in compliance with the following codes:** Uniform Plumbing Code UPC®; National Plumbing Code of Canada; International Plumbing Code IPC®

**Our products conform to the following standards:** ASME A112.19.7, ASME A112.19.15; CSA B45, CSA B45.5; CSA C22.2 No. 218.2; UL-1795; ANSI Z124.1.2

**Our products are listed with:** c ETL us

**IMPORTANT:** Dimensions of fixtures are nominal, may vary and are subject to change or cancellation. No responsibility is assumed for use of superseded or voided leaflet.

*American Standard*